

300 Series TECHNICAL DATA

Maintenance

It is important that all a panic and emergency exit hardware devices are inspected and maintained properly to ensure safety is maintained when exiting a building in any situation.

Once the device is fitted regular maintenance is recommended.

Weekly:

- Make sure the Exit Device functions correctly.
- Any fixings that have worked loose should be re-secured
- Any damaged components should be replaced.
- Ensure there are no obstructions which prevent the panic unit from functioning correctly.

Every three months:

- Check for wear, any visible worn components should be replaced.

Fixing / Installation

Installation instructions are supplied with all the Exidor Panic and Emergency Exit Hardware. Provided the instructions are followed and the units are fitted by a competent person the Exidor range will offer a high degree of safety and security. No responsibility can be accepted by the manufacturer if the installation instructions are not followed.

In order to meet the CEN European Standards the door and frame should be of good quality and suitable to support the hardware.

Make sure that any weather strips or fixings on the door or frame do not interfere with the opening and closing of the door.

All bars and shoots are cut to the exact size on site and each is supplied with loose end plugs and caps. Unless specified all the Exidor range is supplied with all the necessary fixings for timber frames and doors, however for alternative fixings for steel doors please contact the manufacturer or your supplier.

Construction

The main body and slave units are of die cast aluminium with extruded aluminium guides. The internal components and shoot ends are of solid steel with tubular steel shoots and the latch bolts are in extruded brass.

Passivate Protection

The passivate process gives extra protection to the steel components and is recommended when the product is to be used in harsh conditions, such as outside gates, around swimming pools or coastal areas

Chromating

Chromating offers increased protection to the aluminium components, in harsh condition such as coastal areas or swimming pools.

Standard Sizes

Standard sized units are suitable for doors up to 2440mm high and 1220mm wide. The shoot bolts and cross bars can be cut down on site to suit the door height and width.

Non-Standard Shoot Bolt Lengths

For larger doors above 2440mm height special size Top Shoot Bolt lengths are available up on request. The following lengths are stocked by Fred Duncombe Ltd.

- 1210mm for doors up to 2400mm high (Standard size supplied)
- 1600mm for doors up to 2680mm high
- 2100mm for doors up to 3180mm high

Threshold Seal

The ES1 threshold seal plate is for outward opening broad butt hinged doors. The seal has been fully tested with the Exidor range of Vertical Bolts and Pullman Catches so that the CE mark and European CEN Standards EN179 and EN1125 are not compromised. The seal meets the requirements of the Disability Discrimination Act 2004 and has been Fire, Smoke and Acoustic tested.

Fire Rating

The Exidor 300 series range is approved by Certifire for use on Timber and Steel Doors to EN1634-1 : 2000. The rating will depend on the certification of the Fire Door. It is important to realise that the hardware is required for the first part of the test until the door is sealed into the frame, after this period of time the fire door is then responsible for sealing off the area.

Mechanical Code Lock

The Exidor Push Button Mechanical Code Lock allows access from the outside of a door without compromising the safety on the inside. For use with the Exidor 300 series actuator units. See Exidor Code Lock leaflet for details.

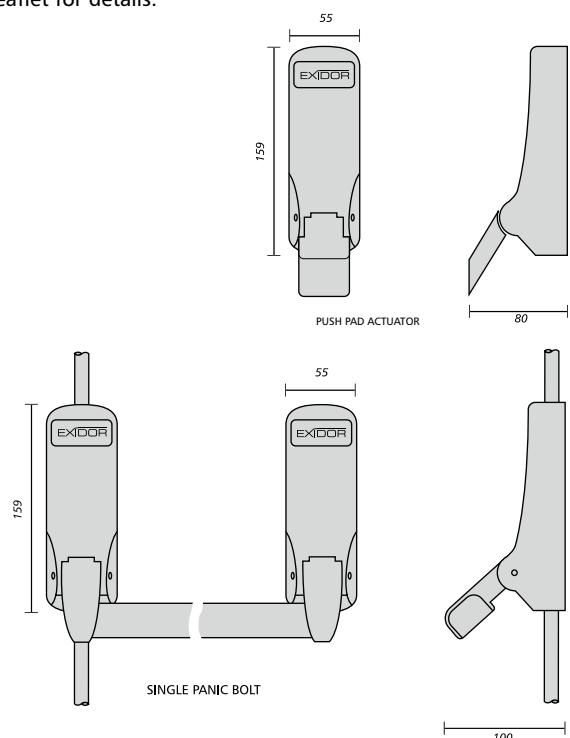

All measurements in mm

300 Series TECHNICAL DATA

Technical Parts List - 300 series

1. Oval Push Bar
2. Top Shoot Tube
3. Bottom Shoot Tube
4. Guide
5. Push Bar Panic Bolt Assembly
6. Slave Unit
7. Push Pad Panic Bolt Assembly
8. Push Bar End Plugs
9. Push Pad Label
10. Foil Label
11. Vertical Pullman Assembly
12. Vertical Pullman Cover
13. Horizontal Pullman Assembly
14. Horizontal Pullman Cover
15. Pullman Keep



CROSS BAR UNITS
 EN1125 : 1997 + A1 : 2001
 Classification No.
 3 7 6 1 1 3 2 2 A

PUSH PAD UNITS
 EN179 : 1997 + A1 : 2001
 Classification No.
 3 7 6 1 1 3 4 2 B

PARTS FOR PUSH BAR PANIC BOLT
 WITH PULLMAN CATCHES

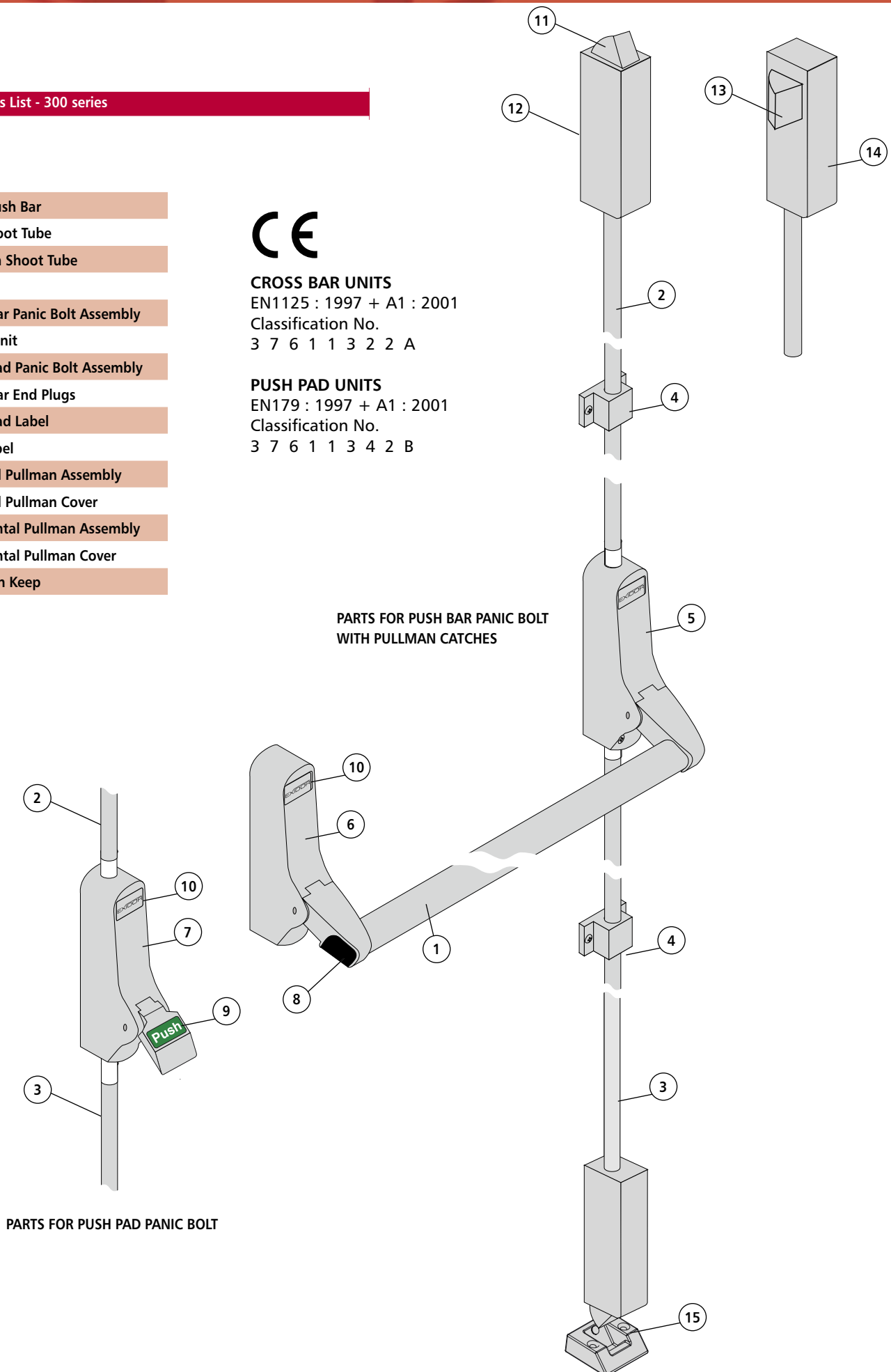

PARTS FOR PUSH PAD PANIC BOLT